

VM215Q

• General Description

VM215Q is a self-biased wideband amplifier operating in the frequency range 2 to 20GHz under 5V. The device is packaged in a 5x5 mm 24 leads Plastic Surface Mount Package (ROHS). This component uses VM215D Vectrawave die.

The device has a small signal gain of 16dB. With a 1dB compression output power of 15dBm. The device contains internal DC block and internal drain bias.

• Features

Frequency range	2 – 20GHz
Single Bias • Internal Drain Bias Input and Output DC block Input and Output 50Ω matched	
Linear Gain	15dB
OP1dB	15dBm
NF	3dB
DC bias:	V_D = +5V, I_b = 75mA
Plastic QFN	5 x 5 (mm) 24 leads

• Applications

- Radar, Electronic warfare
- Microwave Radio & VSAT
- Test and Measurement
- Broadband Communication Infrastructure
- Fiber Optics

• Pins Assignment & Functional Block Diagram

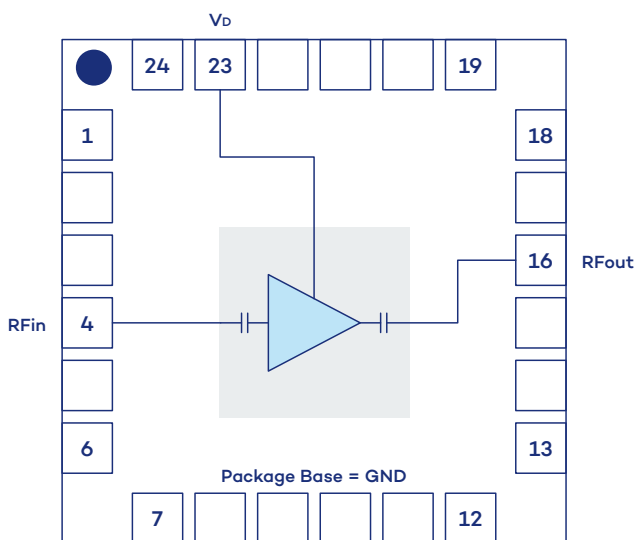

Function	Pin number
RF in	4
RF out	16
V _D	23
Gnd	Exposed Pad

• Electrical Specifications

Test conditions: unless otherwise noted

- Room Temperature = +25°C
- $V_D = +5V$

Symbol	Parameter	Min	Typ	Max	Unit
F	Frequency range	2		20	GHz
G	Linear gain		15		dB
S11	Input return loss		-12		dB
S22	Output return loss		-10		dB
OP1dB	Output Power 1dB compression Point		15		dBm
OIP3	Output Third Order Intermodulation Point		25		dBm
NF	Noise Figure		3	4	dB
I_D	Associated Drain current		75		mA
V_D	Drain voltage		5		V

• Recommended Operating Conditions

Symbol	Parameter	Value	Unit
V_D	Drain voltage	5	V

• Absolute Maximum Ratings

Symbol	Parameter	Value	Unit
V_D	Drain bias voltage	10	V
I_D	Drain bias current	120	mA
P_{in}	Maximum peak input power overdrive	20	dBm
T_j	Junction temperature	-	°C
T_a	Operating temperature range	+25/+85	°C
T_{stg}	Storage temperature range	-55/+150	°C

Operation of this device above any of these parameters may cause permanent damage.

• **Typical Performance**
(Small signal / Board Measurement)

Test conditions: unless otherwise noted

- Reference plane: component access
- $T_{amb} = +25^{\circ}\text{C}$
- $V_D = +5\text{V}$

Gain vs Temperature

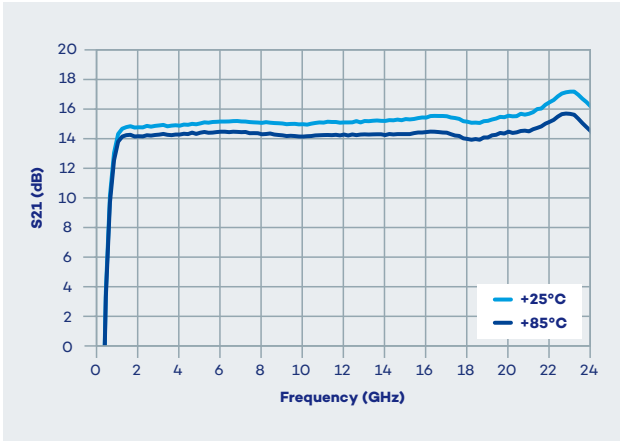

Gain vs V_D

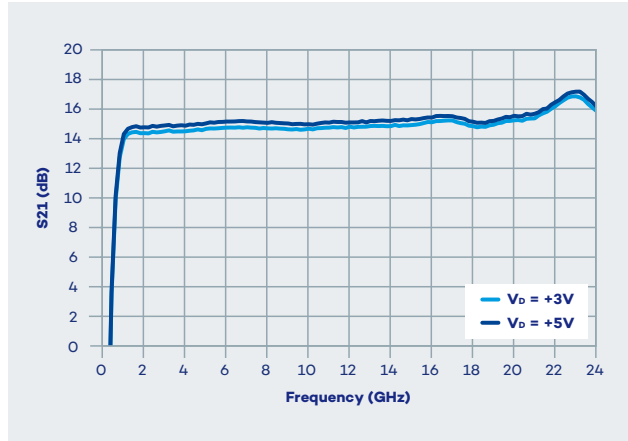

Input Return Loss vs Temperature

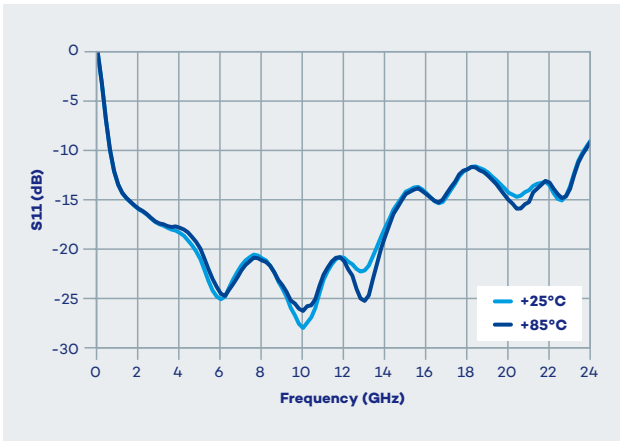

Input Return Loss vs V_D

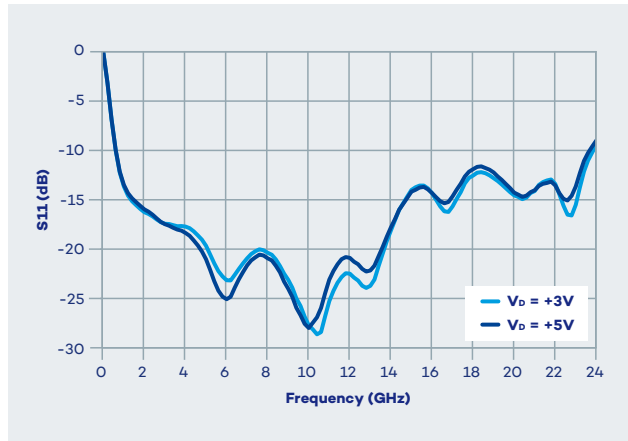

Output Return Loss vs Temperature

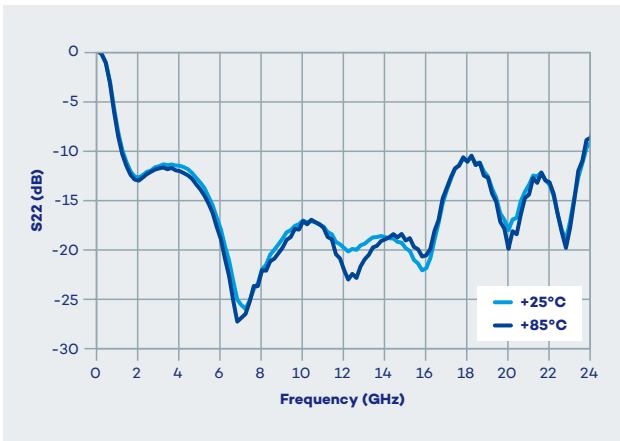

Output Return Loss vs V_D

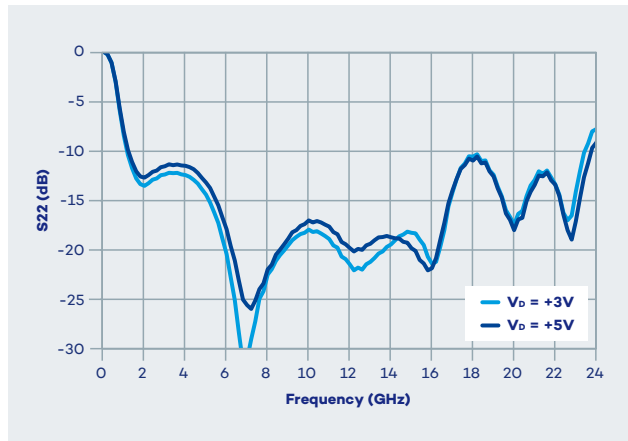

• **Typical Performance**
(Large signal / Board Measurement)

Test conditions: unless otherwise noted

- Reference plane: component access
- $T_{amb} = +25^{\circ}C$
- $V_D = +5V$

Output Power vs Input Power vs Frequency

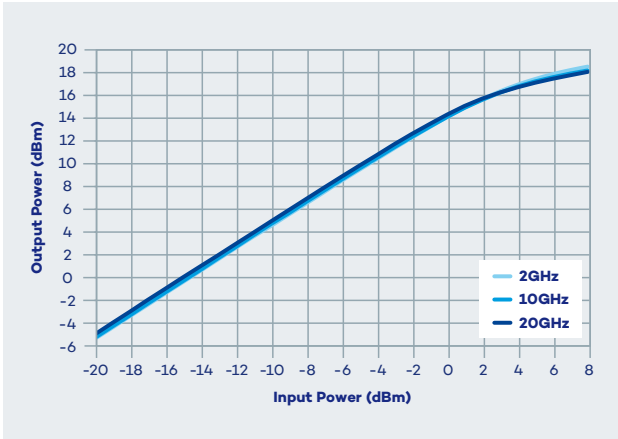

Drain Current vs Frequency

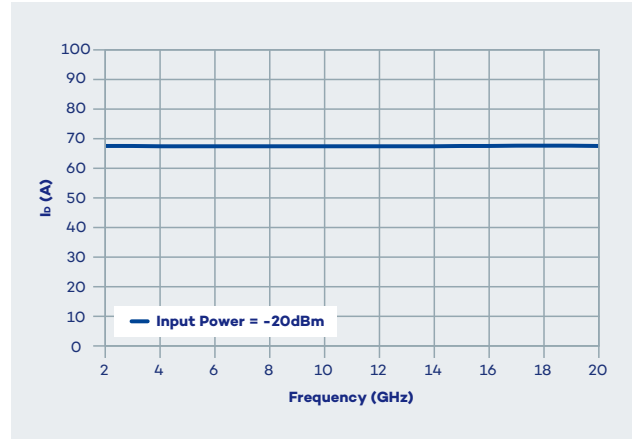

Drain Current vs Input Power vs Frequency

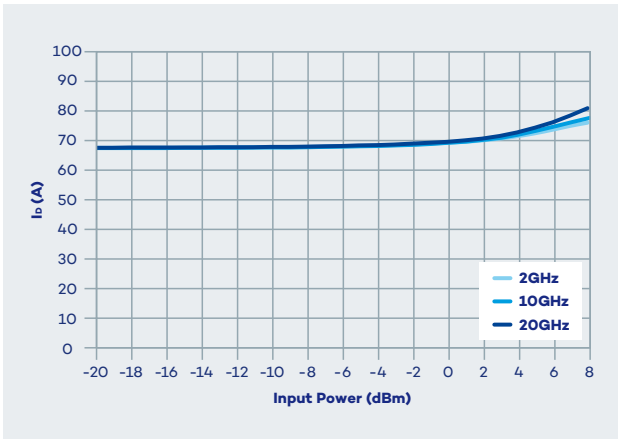

Gain vs Input Power vs Frequency

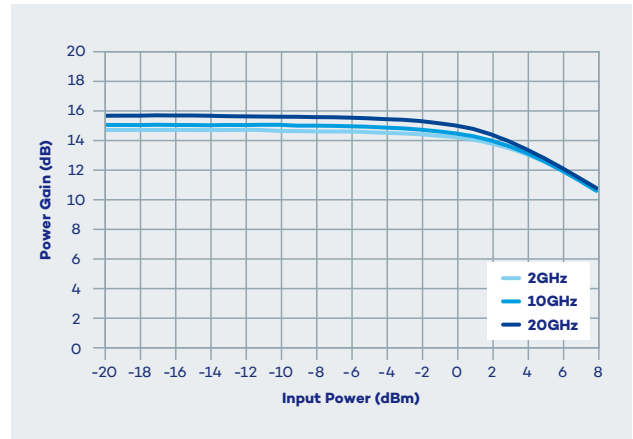

• **Typical Performance**
(Large signal / Board Measurement)

- Test conditions: unless otherwise noted
- Reference plane: component access
- $T_{amb} = +25^{\circ}C$

Output Power vs Input Power vs V_D

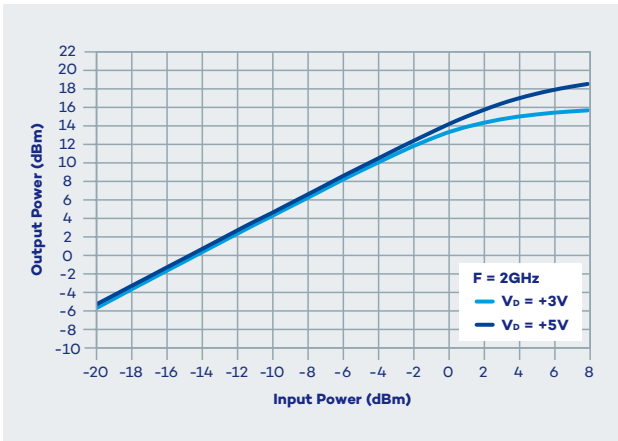

Output Power vs Input Power vs V_D

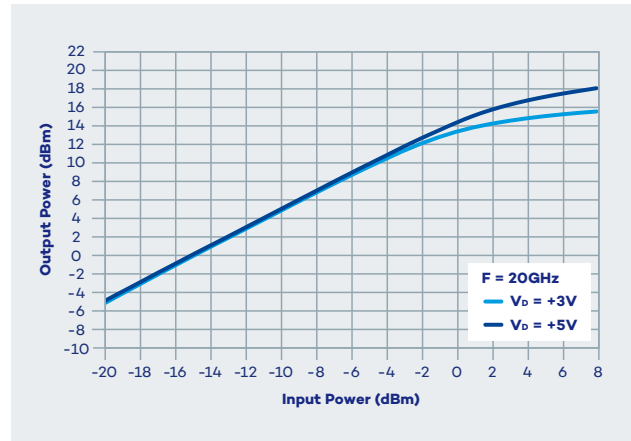

Drain Current vs Input Power vs V_D

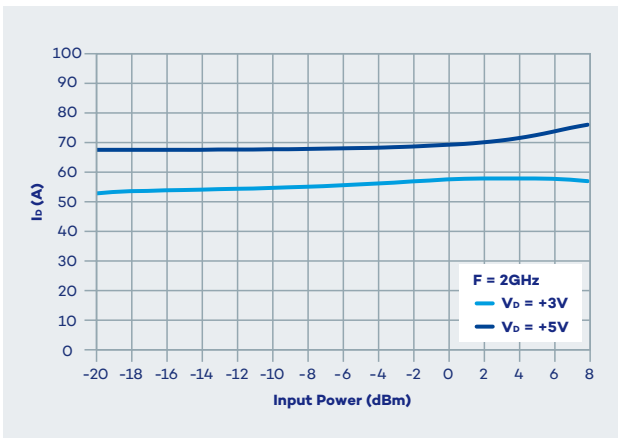

Drain Current vs Input Power vs V_D

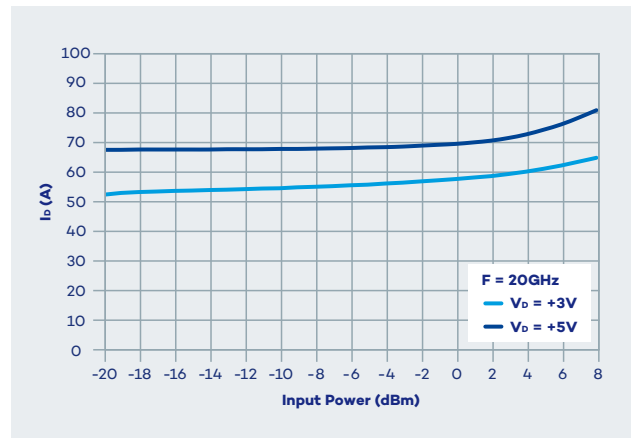

• **Typical Performance**
(Large signal / Board Measurement)

Test conditions: unless otherwise noted

- Reference plane: component access
- $T_{amb} = +25^{\circ}C$
- $V_D = +5V$

Output 1dB Compression point vs Temperature

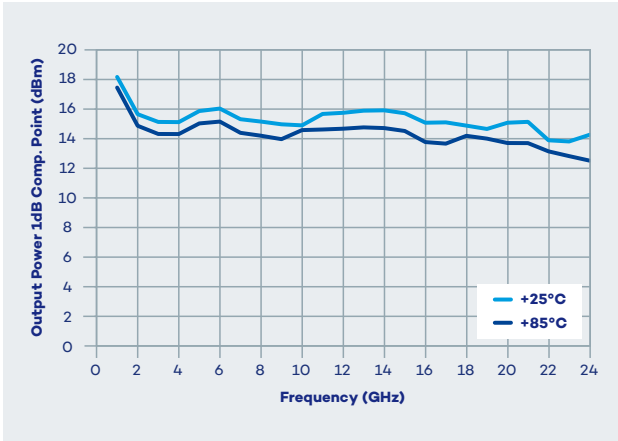

Output 1dB Compression point vs V_D

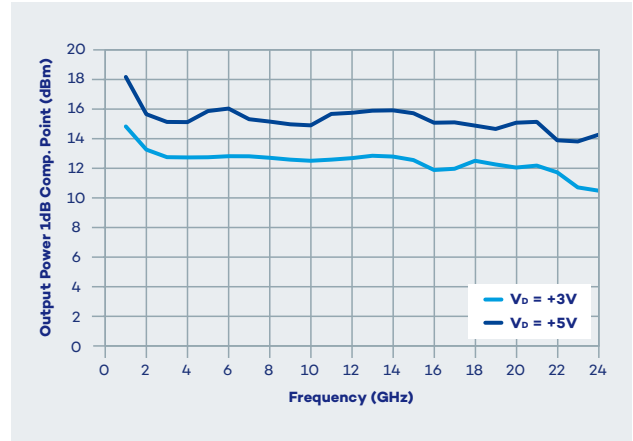

Noise Figure vs Frequency vs V_D

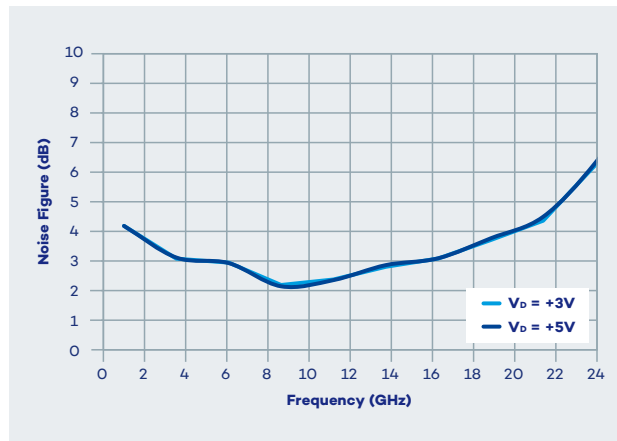

• **Application circuit**

• C1 = 1μF

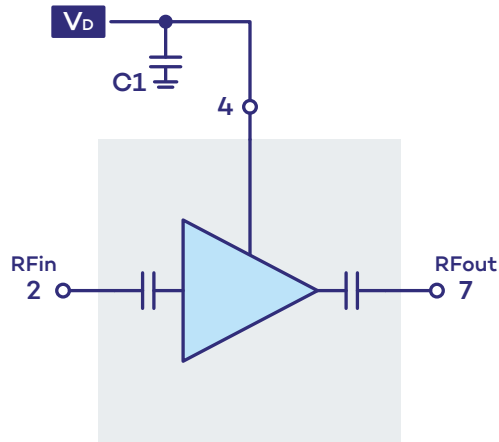

• **Mechanical drawing**

QFN exposed PAD must be connected to ground (RF and DC).

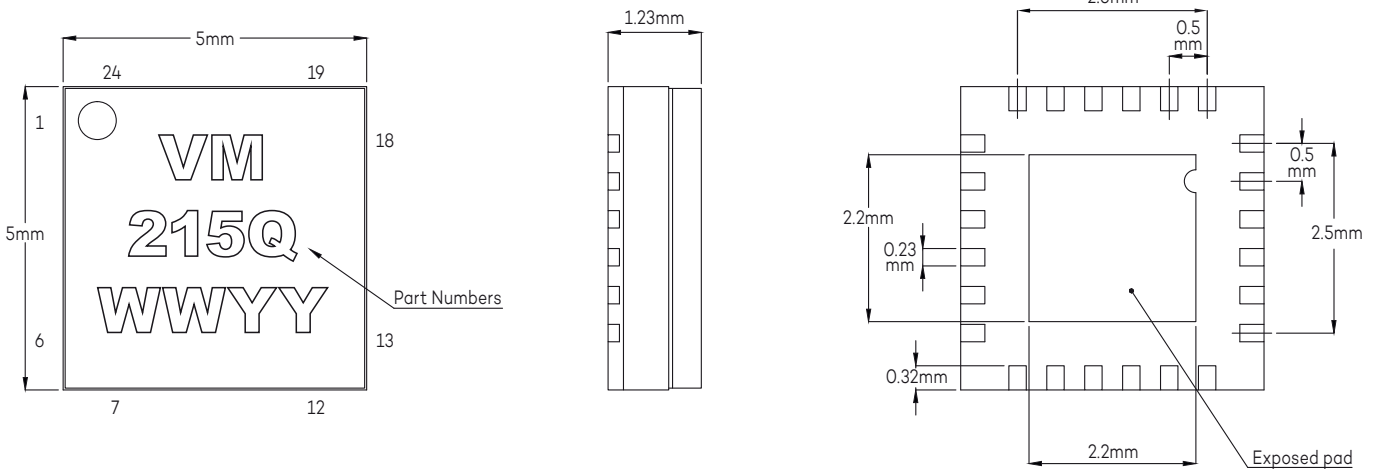

• Ordering information

Product Code	Parameter
VM215Q	2 to 20GHz WideBand Amplifier in QFN format

• Associated Material

- Evaluation Board
- Mechanical files (DXF)

• Product Compliance Information

Solderability

Solder Stencil thickness: 127µm

Solder: SAC 305 (ROHS)

Temperature profile example: maximum recommended reflow profile (leadfree)

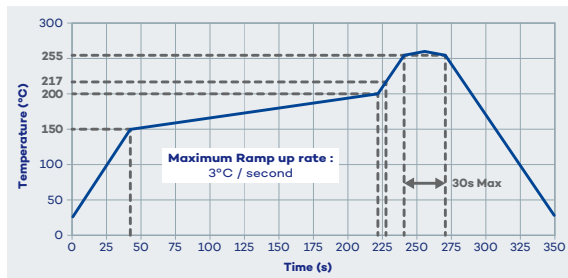

RoHS-Compliance

This part is compliant with EU 2011/65/EU RoHS directive (Restrictions on the Use of Certain Hazardous Substances in Electrical and Electronic Equipment).

Other attributes

- Lead Free
- Halogen Free (Chlorine, Bromine)
- Antimony Free
- TBBP-A (C15H12Br4O2) Free
- PFOS Free
- SVHC Free

ESD Sensitivity Rating

Test: Human Body Model (HBM)

Std: JEDEC Standard JESD22-A114



• Contact information

For the latest specifications, additional product information, worldwide sales and distribution locations, and information about Vectrawave.

vectrawave.com

+33 (0)2 57 63 00 20

sales@vectrawave.com

Vectrawave Device

5, rue de Louis de Broglie
22300 Lannion
France

Informations contained in this document, are considered to be accurate and reliable. However, no responsibility is assumed by Vectrawave for the consequence of its use, nor for any infringement of patents or other rights of third parties that may result from this use. Products are not authorized for use in life support devices without prior written approval from Vectrawave. Specifications are subject to changewithout notice